

Solid Edge 2D Drafting

Robust 2D design application – at no cost

Benefits

- Save time and money with a cost-effective, high-value solution for 2D tasks
- Continue to make use of 2D legacy data
- Stop paying for upgrades and subscriptions
- Download regular updates for free
- Standardize on a single platform, reducing training and maintenance costs
- Share native drawings with suppliers for design review or manufacture

Features

- Production-proven 2D drafting
- Fast and easy parametric drawing layout
- Annotation and dimensioning that complies to world standards
- Diagramming for electrical and other schematics
- Translation wizards from AutoCAD and other 2D products
- Free to download and use
- Goal Seek for solving free-body diagrams

Summary

Solid Edge® 2D Drafting software delivers a production-proven set of capabilities for creating 2D documentation. This free application is available for download anywhere in the world. Solid Edge 2D Drafting offers excellent drawing layout, diagramming, annotation and dimensioning controls that automatically comply with a wide range of drafting standards – including ISO, ANSI, BSI, DIN, JIS and UNI. Visit www.solidedge.com/free2d to download your free software and learn more.

Streamlined drawing creation

Solid Edge 2D Drafting demonstrates Siemens PLM Software's commitment to helping companies control costs. Whether you are using 2D company-wide or for specific 2D design processes, you will benefit from Solid Edge 2D Drafting. Solid Edge 2D Drafting capitalizes on years of production-proven capabilities developed for Solid Edge.

The innovative user interface includes SmartStep, which conveniently guides you through each command step. You have easy access to all inputs, quickly increasing your productivity. A new Ribbon lists the most common operations on a "Home" tab for fast command access.

Intelligent 2D parametric relationships can be applied to geometry as it is created or added later in the process. Relationships ensure the design intent is maintained. Line end connections, curve tangencies, parallel or perpendicular conditions, formula-driven dimensions ($\text{Dim1} = \text{Dim2} + 50$) – these are just a few of the relationships you can apply to geometry. This

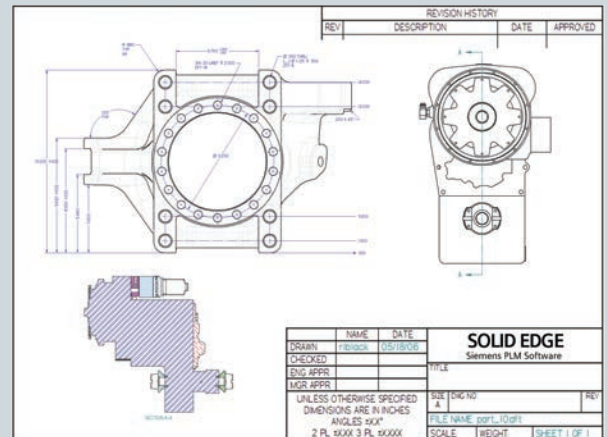

SOLID EDGE

www.siemens.com/solidedge

SIEMENS

Solid Edge 2D Drafting

intelligence is maintained across multiple views so that changing a diameter in a top view will automatically change the associated lines in adjacent orthographic views.

Solid Edge 2D Drafting includes comprehensive dimensioning and annotating tools that enable you to quickly create fully detailed drawings in seconds. With Solid Edge, you have full control over every element of your drawings, ensuring the requirements of organizational and international standards are met. Intuitive “grid” tools allow you to quickly sketch your designs with precision using a full suite of drawing tools that enable you to create all the geometric elements you require, including circles, arcs and curves in any style or color.

Preserve and maintain your existing drawings

In Solid Edge 2D Drafting, you can continue to make full use of your existing 2D legacy data. Intuitive wizards provide robust translation of existing 2D files such as AutoCAD, while 2D drafting tools not only emulate the workflows you already know but offer additional capabilities as well. Solid Edge also provides a familiar process for generating detailed drawings from 2D layouts. Similar in concept to the model and paper space methodology in other 2D products, 2D layouts are designed at 1:1 scale.

Multiple detail views of the layout are then created on separate drawing sheets. Each view can be scaled as required, while still maintaining correct dimensions and annotations. Any changes to the original 2D layout are automatically reflected in the detail views. These and many other customer-driven capabilities make Solid Edge 2D Drafting a compelling application for AutoCAD 2D users looking for more value and productivity from their 2D CAD seats.

Diagramming

Solid Edge 2D Drafting features “drag and drop” diagramming capabilities using industry standard symbols (blocks) to automate the creation of 2D diagrams, such as those commonly produced for

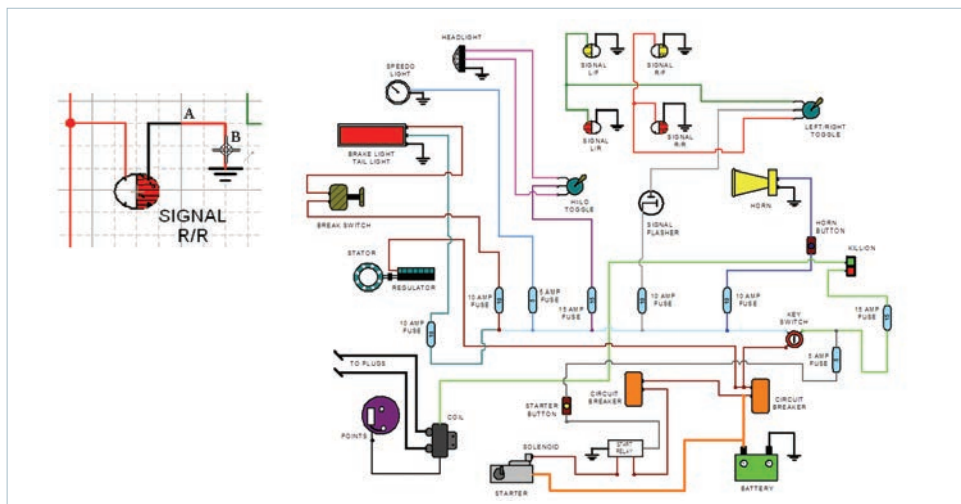

electrical and P&ID layouts – without the need for dedicated schematic software. Blocks can support multiple occurrences of the same component and can represent alternate positions to ensure a correct bill of materials. Not only does Solid Edge 2D Drafting deliver extensive built-in libraries – but you can use your existing block libraries without translation.

Goal Seek

The Goal Seek functionality in Solid Edge provides a handy tool to simplify problem solving. Goal Seek combines a familiar free-body diagram approach with a powerful 2D parametric sketch solver to compute the geometry of the diagram. Users simply sketch the system in 2D, add some dimensions and any defining

constraints and the system solves for the desired parameter – hence the term Goal Seek. Solid Edge computes and stores the most common measurements such as distance, angles, perimeters and areas for fast problem definition, and includes intrinsic functions for doing math and trig operations needed in complex equations.

Designers can realize significant downstream benefits by utilizing this simple but effective tool. Goal Seek eliminates the need to rearrange equations and, in many cases, removes the need to even develop equations. The results can ultimately control the size and position of 3D geometry and components, thus retaining the initial intelligence throughout the design process.

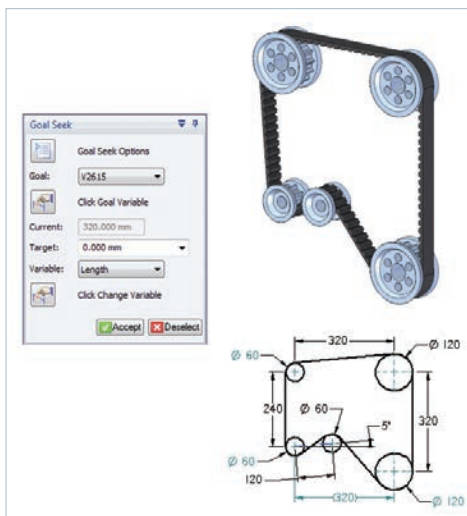

Access to online support

This free download includes access to a dedicated support forum. Post questions, share ideas and learn tips from experts and other users. You can access the Solid Edge 2D Drafting forum via a web browser by following these instructions:

1. Visit: <http://www.siemens.com/gtac/bbs>
2. Your username is the email address you provided when you registered for Solid Edge 2D Drafting and the password is “free2d” (case sensitive and without the quotes).

If you have any questions on how to install or use the software, utilize this support forum.

Higher productivity, lower costs

Solid Edge 2D Drafting allows Solid Edge customers to standardize on a single platform, reducing maintenance and training costs. You can share native Solid Edge drawings with your suppliers free of translation requirements while ensuring data integrity. Software maintenance with API and automatic updates is also available to Solid Edge customers.

Keep your costs low with Solid Edge 2D Drafting, but easily move to 3D when more automated design is required – all on a single platform. Your data created in Solid Edge 2D Drafting can be used for 3D design in Solid Edge – without fear of data loss or rework. You can produce superior visualizations for customer proposals, perform part-to-part interference checking for accurate preproduction designs, even use your models in downstream simulation and manufacturing applications. And with a 3D model you can generate automatic 2D drawings featuring orthogonal, section and detail views, dimension retrieval as well as automated parts lists. No matter where you are or where you want to go, Solid Edge 2D Drafting will help you design better.

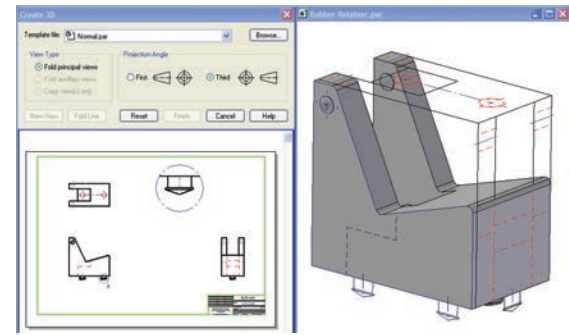

Contact
 Siemens Industry Software
 Americas +1 800 807 2200
 Europe +44 (0) 1202 243455
 Asia-Pacific +852 2230 3308

www.siemens.com/plm

© 2012 Siemens Product Lifecycle Management Software Inc. All rights reserved. Siemens and the Siemens logo are registered trademarks of Siemens AG. D-Cubed, Femap, Geolus, GO PLM, I-deas, Insight, JT, NX, Parasolid, Solid Edge, Teamcenter, Tecnomatix and Velocity Series are trademarks or registered trademarks of Siemens Product Lifecycle Management Software Inc. or its subsidiaries in the United States and in other countries. All other logos, trademarks, registered trademarks or service marks used herein are the property of their respective holders.
 X18 8799 2/12 C